



SAFETY

A COMMITMENT TO SAFETY

SandenVendo America, Inc. is committed to safety in every aspect of our product design. SandenVendo America, Inc. is committed to alerting every user to the possible dangers involved in improper handling or maintenance of our equipment. The servicing of any electrical or mechanical device involves **potential hazards**, both to those servicing the equipment and to users of the equipment. These hazards can arise because of improper maintenance techniques. The purpose of this manual is to alert everyone servicing SandenVendo America, Inc. equipment of potentially hazardous areas, and to provide **basic safety guidelines** for proper maintenance.

This manual contains various **warnings** that should be carefully read to minimize the risk of personal injury to service personnel. This manual also contains service information to insure that proper methods are followed to avoid damaging the vendor or making it unsafe. It is also important to understand these **warnings** are not exhaustive. SandenVendo America, Inc. could not possibly know, evaluate, or advise of all of the conceivable ways in which service might be done. Nor can SandenVendo America, Inc. predict all of the possible hazardous results. The safety precautions outlined in this manual provide the basis for an effective safety program. Use these precautions, along with the service manual, when installing or servicing the vendor.

We strongly recommend a similar commitment to safety by every servicing organization. Only **properly-trained personnel should have access to the interior of the machine**. This will minimize the potential hazards that are inherent in electrical and mechanical devices. SandenVendo America, Inc. has no control over the machine once it leaves the premises. It is the owner or lessor's responsibility to maintain the vendor in a safe condition. See Section I of this manual for proper installation procedures and refer to the appropriate service manual for recommended maintenance procedures. If you have any questions, please contact the Technical Services Department of the SandenVendo America, Inc. office nearest you.

SAFETY RULES

- Read the Safety Manual before installation or service.
- Test for proper grounding before installing to reduce the risk of electrical shock and fire.
- Turn off power switch or disconnect power cord from wall outlet before servicing or clearing product jams. The vending mechanism can trap and pinch hands.
- Use only fully-trained service technicians for Power- On servicing.
- Remove any product prior to moving a vendor.
- Use adequate equipment when moving a vendor.
- Always wear eye protection, and protect your hands, face, and body when working near the refrigeration system.
- Use only authorized replacement parts.
- Be aware of inherent dangers in rocking or tipping a vending machine.
- Always turn power off before plugging or unplugging vendor to wall outlet.

SECTION I: VENDOR INSTALLATION

- A. Vendors are large, bulky machines of significant size and weight. Improper handling can result in injury. When moving a vendor, carefully plan the route to be taken and the people and equipment required to accomplish the task safely.
- B. Remove all tape, shipping sealant, and Styrofoam from the vendor. Loosen any shipping devices used to secure interior parts during shipping. Remove the wooden shipping base attached to the vendor base by the vendor leveling screws. Make certain the leveling screws are in place and functional.
- C. Position the vendor three to four inches (7.6 cm to 10.2 cm) from a well-constructed wall (of a building or otherwise) on a flat, smooth surface.

IMPORTANT: *The vendor requires three inches (7.6 cm) of air space from the wall to ensure proper air circulation to cool the refrigeration unit.*

- D. Adjust the leveling screws to compensate for any irregularities on the floor surface. Ideally, no adjustment will be necessary and the leveling legs will be flush with the bottom of the vendor. A spirit level is a useful aid to level the vendor. When the outer door is open, it will remain stationary if the vendor is properly leveled. Vendors must be level to ensure proper operation and to maintain stability characteristics. Do not add legs to the vendor. **The leveling legs shall not raise the vendor more than 1 1/8 inch above the ground.**
- E. Check the manufacturer's nameplate on the left or right side of the vendor's outer door to verify the main power supply requirements of the vendor. Be sure the main power supply matches the requirements of the vendor. To ensure safe operation, plug the vendor only into a properly grounded outlet.
DO NOT USE EXTENSION CORDS.
- F. Recommended voltage specs = 115V ± 10%
- G. Dedicated 15A service required for 1 machine.

NOTE: Any power supply variance more than + 10% may cause the vendor to malfunction.

- * Power outlets must be properly **grounded**.
- * Power outlets must be properly **polarized**, where applicable.
- * Test the outlets using the following information.
(Refer to Figure 1 on Page S-4.)

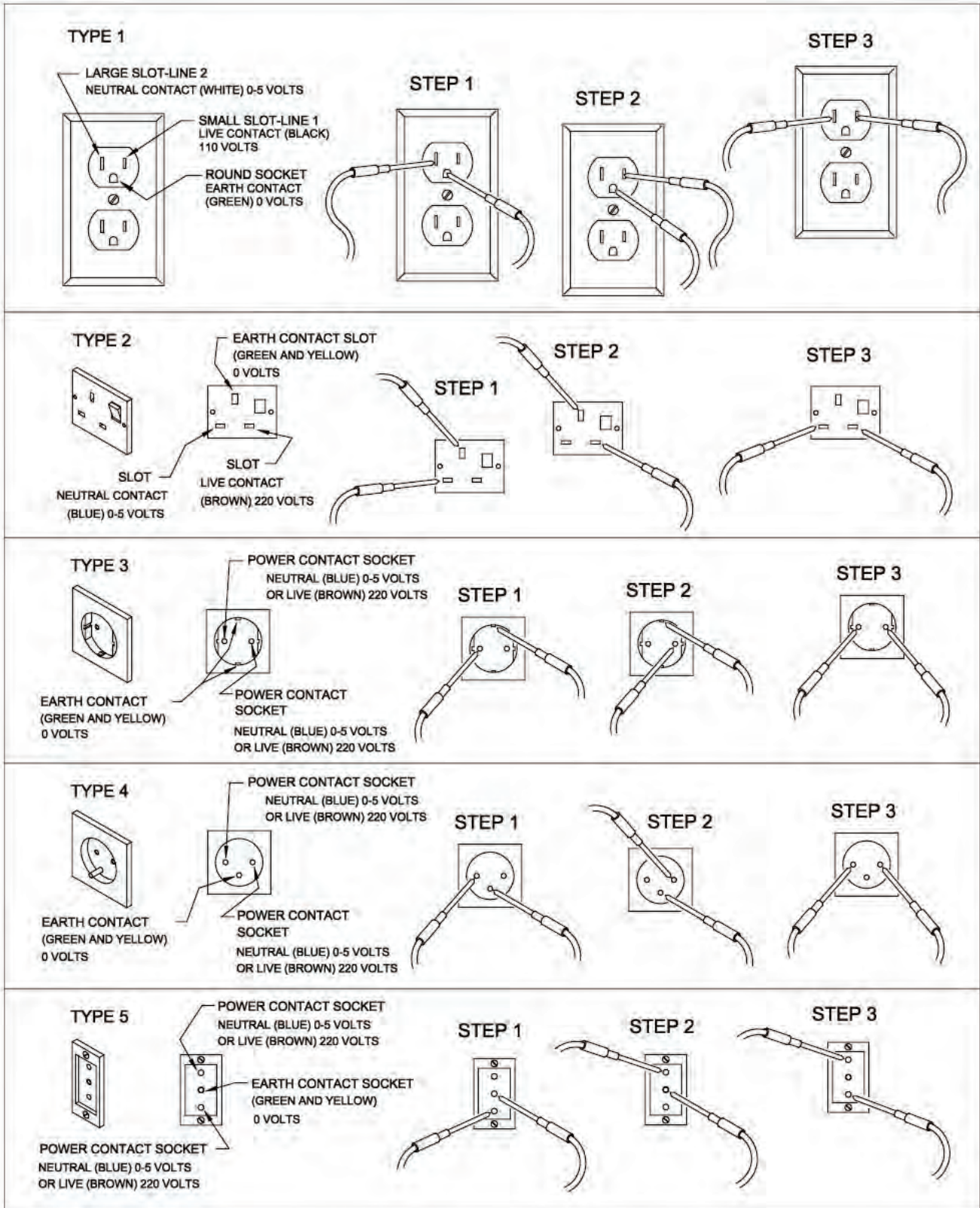

SECTION I: VENDOR INSTALLATION (CONTINUED)

For Type 1 and Type 2 outlets, test for Grounding and Polarization as follows:

1. With a test device (volt meter or test light), connect one probe to the receptacle's neutral contact and the other to the live contact. The test device should show a reaction.
2. Connect one probe to the receptacle's earth contact and the other to the live contact. The test device should show a reaction.

For Type 3 through Type 5 outlets, test for Grounding as follows:

1. With a test device (volt meter or test light), determine which of the receptacle's power contacts is the live contact.
 - A. Connect one probe to the receptacle's earth contact.
 - B. Connect the second probe to the left (or upper) power contact. If a reaction occurs, this is the live power contact. If a reaction does not occur, move the second probe to the right (or lower) contact. A reaction should occur, indicating that this is the live power contact.
2. Connect one probe to the receptacle's live power contact (as determined in step 1). Connect the second probe to the other power contact (neutral). The test device should show a reaction.

IF THE ABOVE CONDITIONS ARE NOT MET FOR THE GIVEN OUTLET TYPE, CONTACT A LICENSED ELECTRICIAN AND HAVE THE NECESSARY CORRECTIONS MADE.

H. Electronic Power Lock

The auxiliary, (back-up battery pack), voltage is specified by the lock manufacturer to be 24-30 Volts DC. This is typically provided by a back-up battery pack with (3) 9-volt commercially available alkaline batteries.

SECTION I: VENDOR INSTALLATION (CONTINUED)

I. Door Support (Figure 2)

The door support is to ensure that the outer door closes squarely to the cabinet. Raising the door can also ensure proper alignment of the door latch.

FIGURE 2

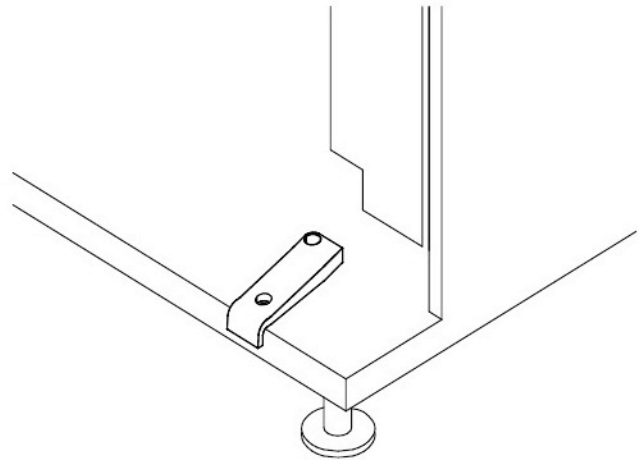

J. Door Latch Alignment (Figure 3)

After any door adjustment, the floating quicker lock assembly should align itself automatically. The latch assembly is adjustable. To adjust, loosen the latch bracket mounting screws, raise or lower the latch assembly into position, then tighten the mounting screws.

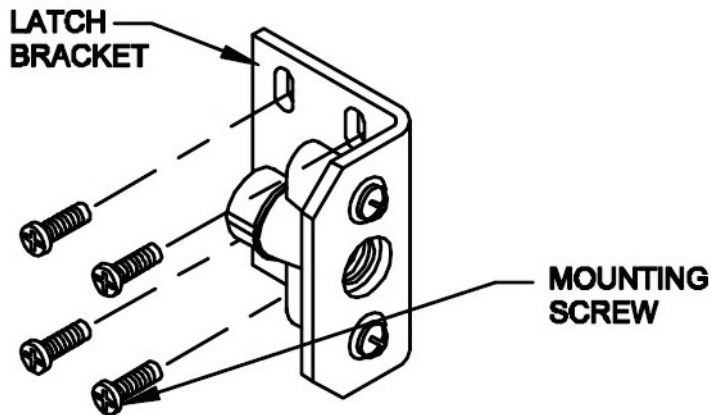

FIGURE 3



WARNING:
KEEP FINGERS AND OTHER OBJECTS OUT OF LOCK CAVITY

NOTE: Refer to the appropriate parts and service manual for detailed instructions, operating principles, and recommended maintenance intervals and procedures.

SECTION II: ELECTRICAL HAZARDS

GENERAL

SandenVendo America, Inc. vending machines are provided with the appropriate power supply setting for your area. Some models are equipped with step-down transformers, as required. This enables the vending machine to operate on different main voltages. Refer to Section I. E. for information to determine the main power requirements. Refer to the appropriate service manual for details of step-down transformer operations.

The power sources just mentioned are standard for both household and commercial lighting and appliances. However, careless or improper handling of electrical circuits can result in injury or death. Anyone installing, repairing, loading, opening, or otherwise servicing a vending machine should be alerted to this point. Apply all of the normal precautions observed in handling electrical circuits, such as:

- Refrigeration servicing to be performed by qualified personnel only.
- Unplug the vendor or move power switch to off position before servicing or clearing product jams.
- Replace electrical cords if there is any evidence of fraying or other damage.
- Keep all protective covers and ground wires in place.
- Plug equipment into outlets that are properly grounded and polarized (where applicable), and protected with fuses or circuit breakers.
- All electrical connections must be dry and free of moisture before applying power.

A. Grounding Systems

SandenVendo America, Inc. vending machines are provided with the appropriate service cord for the power supply in your area. The service cord will connect to the matching electrical outlet. Always ensure that the outlet to be used is properly grounded before plugging in the vendor. (See pages S-3 through S-5.)

WARNING:
**ALWAYS TEST TO VERIFY PROPER GROUNDING PRIOR
TO INSTALLATION TO REDUCE THE RISK OF ELECTRICAL
SHOCK AND FIRE**

The electrical grounding system also includes the bonding of all metal components within the vendor. This involves a system of bonding wires identified by green or green and yellow marking. The system uses serrated head screws, lock washers, and star washers to ensure the electrical connection between parts. Maintenance of vending equipment may involve disassembly. Include the above items when reassembling, even if the vending machine may appear to function normally without them. Omitting any of these items can compromise a link in the grounding system. See the appropriate service manual or kit instructions for components and assembly instructions.

SECTION II: ELECTRICAL HAZARDS (CONTINUED)

B. Servicing with “Power Off”

For maximum safety, unplug the service cord from the wall outlet before opening the vendor door. This will remove power from the equipment and avoid electrical and mechanical hazards. Service personnel should remain aware of possible hazards from hot components even though electrical power is off. See the appropriate sections of this manual for further information.

C. Servicing with “Power On”

Some service situations may require access with the power on. Power on servicing should be performed only by fully-qualified service technicians. Particular caution is required in servicing assemblies that combine electrical power and mechanical movement. Sudden movement (to escape mechanical action) can result in contact with live circuits and vice versa. It is therefore doubly important to maintain maximum clearances from both moving parts and live circuits when servicing.

WARNING:
**“POWER ON” SERVICING SHOULD BE ACCOMPLISHED ONLY
BY FULLY-TRAINED PERSONNEL. SUCH SERVICE BY
UNQUALIFIED INDIVIDUALS CAN BE DANGEROUS.**

Power to lighting and refrigeration system is shut off automatically by the electronic controller when the outer door is opened.

NOTE: For power-on servicing of the vendor’s lighting system, turn lighting power on by accessing the Lights test function of the electronic controller (see programming on inner door). For power-on servicing of the vendor’s refrigeration system, turn refrigeration power on by accessing the Compressor test function of the electronic controller (see programming on inner door).

SECTION III: MECHANICAL HAZARDS

A. Servicing of Moving Parts and Assemblies

When servicing assemblies involving moving parts, **use extreme caution!!** Keep fingers, hands, loose clothing, hair, tools, or any foreign material clear of entrapment.

As noted before under the electrical hazards section, Power On servicing should only be performed by qualified personnel. Refer to and heed the warnings noted in the electrical hazards section. These warnings refer to the potential hazards associated with electrical power and moving parts. Always maintain maximum clearances from electrical and moving parts.

Always install protective covers and guards when reassembling equipment.

WARNING:
THIS VENDING MACHINE INCLUDES MECHANICAL EQUIPMENT
WHICH CAN BE HAZARDOUS IF IMPROPERLY HANDLED OR
SERVICED. USE CAUTION AND CONSULT THE SandenVendo
America, Inc. SAFETY MANUAL AND SandenVendo America, Inc.
SERVICE MANUAL FOR ADDITIONAL SAFETY INFORMATION.



SECTION IV: REFRIGERATION HAZARDS

GENERAL

Refrigeration systems involve both electrical power and mechanical action. These systems may present any of the potential dangers shown in the sections on electrical and mechanical hazards contained in this manual. See Sections II and III for further information.

A. Compressed Refrigerant

Refrigeration systems involve the compression and evaporation of gases. The pressures contained represent a potential hazard if suddenly released in confined areas. Caution is required when performing maintenance tests or repairs. All testing of sealed refrigeration systems must be done by trained personnel who are familiar with the systems and pressures involved.

B. Physical Protection

The accidental release of refrigerant gases can result in physical injuries. Always wear protective glasses and protect your hands, face, and body when working near the refrigeration system.

WARNING:
**ALWAYS WEAR EYE PROTECTION AND PROTECT YOUR HANDS, FACE,
AND BODY WHEN WORKING NEAR THE REFRIGERATION SYSTEM**

SECTION V: TEMPERATURE HAZARDS

GENERAL

Maintenance personnel should be alerted to the potential hazards from hot metal surfaces. High temperatures may be present throughout the refrigeration system even though electrical power has been removed.

SECTION VI: SUBSTITUTIONS AND MODIFICATIONS

GENERAL

Unauthorized changes or the substitution of unauthorized parts can compromise the equipment designs. This can result in unsafe conditions for either the service personnel or the equipment users. Always refer to the appropriate parts and service manual for replacement parts and maintenance instructions. If questions arise, contact the Technical Services Department of the SandenVendo America, Inc. office in your area.

When servicing the vending machine, always reassemble all components to their original location and position. Maintain the correct routing for tubing, electrical wiring, etc. Replace all clamps, brackets, and guides to their original locations. Replace all tubing, sleeving, insulating material, and protective covers to their original condition.

WARNING:

SandenVendo America, Inc. EQUIPMENT HAS BEEN PROVIDED WITH APPROPRIATE PROTECTIVE DEVICES TO PROTECT AGAINST THE POSSIBILITY OF OVERHEATING AND FIRE AS A RESULT OF EQUIPMENT OR COMPONENT FAILURES. SUBSTITUTION, MODIFICATION, OR BYPASSING OF SUCH PROTECTIVE DEVICES CAN CREATE DANGEROUS CONDITIONS. PROTECTIVE CIRCUITS SHOULD NEVER BE BYPASSED, AND FAILED PROTECTIVE DEVICES MUST BE REPLACED ONLY WITH FACTORY-AUTHORIZED PARTS.

A. Service Cord Replacement

SandenVendo America, Inc. vending machines are furnished with unique power supply cords. If replacement becomes necessary, consult the appropriate parts and service manual and order the correct replacement cord for the model of vending machine in question. Do not use substitute replacement cords. Only authorized service personnel with appropriate training should replace the vending machine service cord. If a question should arise concerning which service cord to order, contact the Technical Services Department of the SandenVendo America, Inc. office in your area.

SECTION VII: SUBSTITUTIONS AND MODIFICATIONS (CONTINUED)

WARNING:
THIS APPLIANCE MUST BE EARTHED. IMPORTANT!

The wires in the main leads are colored in accordance with the following code:

| 110v/120v | 220v/240v |
|------------------|-------------------------------------|
| Green | Green and Yellow Earth |
| White | Blue Neutral |
| Black | Brown Live |

SECTION VIII: CONSUMER SAFETY WARNING

WARNING:
**VENDOR CAN BE OVERTURNED IF SUFFICIENT FORCE IS APPLIED
AND MAY RESULT IN SERIOUS INJURY OR DEATH.**

GENERAL

There have been incidents, including fatalities, when vending machines have been vandalized by being pulled over in an attempt to obtain free product or money. To warn of the danger involved in tipping, shaking, or rocking the vending machine, a decal has been designed to be affixed to vending machines. (One such decal is applied on the vending machine.) SandenVendo America, Inc. will supply sufficient decals to be placed on all machines, on request. If you have any questions, contact the Technical Services Department of the SandenVendo America, Inc. office in your area.

**THE FOLLOWING DECAL SHOULD BE PLACED IN A POSITION ON THE
VENDOR CONTROL PANEL AT EYE LEVEL**

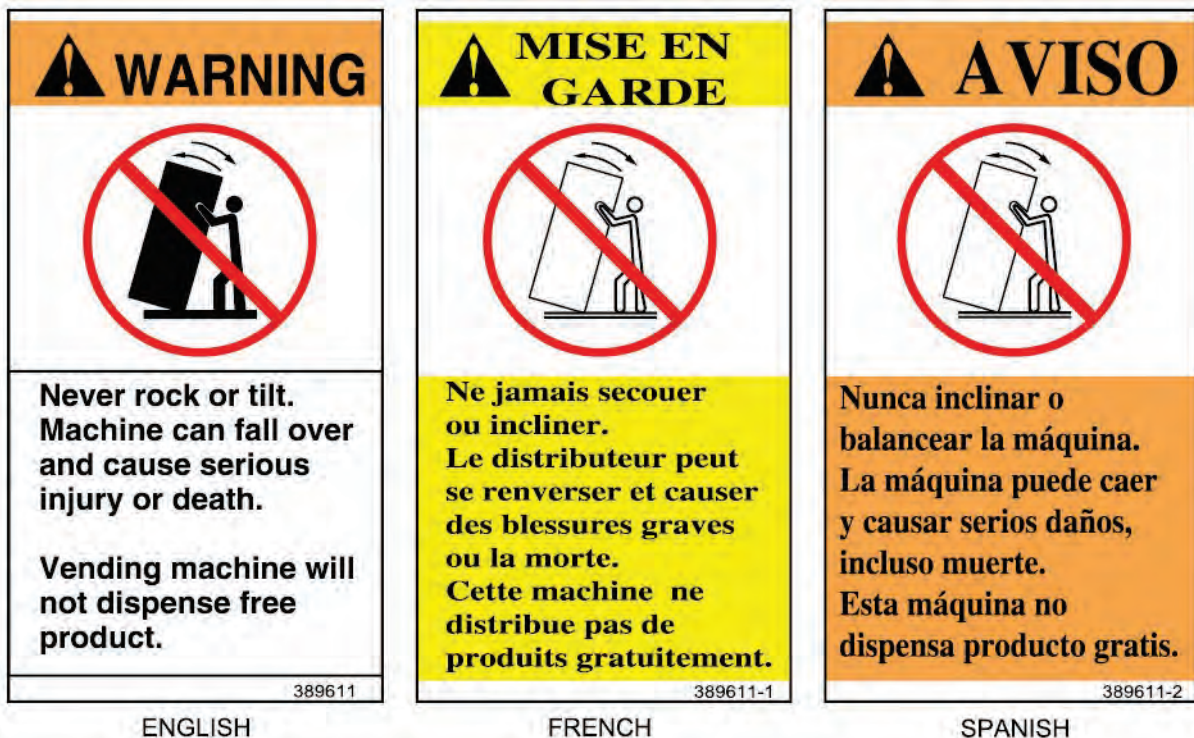

| AREA | ADDRESS | PHONE NUMBERS |
|--|---|---|
| United States, Canada | SandenVendo America, Inc. 10710 Sanden Drive Dallas, TX 75238-1335 U.S.A. | Tel: (800) 344-7216 Fax: (800) 541-5684 |
| Japan | Sanden International Corporation 31-7 Taito 1-Chome Taito-ku Tokyo 110, Japan | Tel: (81) 3-3835-1321 Fax: (81) 3-3833-7096 |
| Europe, Mid-East, Africa, Mid-Asia | Vendo GMBH Spangerstr. 22, P.O. Box 130940 40599 Dusseldorf Germany | Tel: (49) 211-74-039-0 Fax: (49) 211-7488541 |
| Australia, New Zealand | Sanden International Pty. Ltd. 54 Allingham St., Condell Park N.S.W. 2200 Australia | Tel: 61-2-9791-0999 Fax: 61-2-9791-9029 |
| Singapore, Hong Kong, Indonesia, Philippines, India | Sanden International (Singapore) Pte., Ltd. Sanden House, 25, Ang Mo Kio St. 65 Singapore 569062 The Republic of Singapore | Tel: 65-482-5500 Fax: 65-482-1697 |
| Taiwan | Sanden International Taiwan Corp. No, 21-6, Sec 1 Tun Hwa S. Rd., Taipei, Taiwan Taiwan, ROC | Tel: 886-2-570-6106 Fax: 886-2-577-1959 |
| Belgium | N.V. Vendo Benelux, S.A. Industrial Research Park N.O.H. 13 Font St. Landry 1120 Brussels Belgium | Tel: 32-2-268-2595 Fax: 32-2-268-2862 |
| England | Vendo UK Ltd. Vendo House Kingsclere Road Basingstoke, Hants RG21, 5GU Great Britain | Tel: 44-1256-479309 Fax: 44-1256-844469 |
| Italy | Vendo Italy S.p.A. Casella Postale 9 1-15033 Casale Monferrato Italy | Tel: 39-142-335111 Fax: 39-142-5623-48 |
| Spain | Vendo Iberia, S.A. C/ Sant Ferran No. 92 Poligono Industrial la Almeda, Sector P-1 08940 Cornellà, (Barcelona), Spain | Tel: 343-474-1555 Fax: 343-474-1842 |

| AREA | ADDRESS | PHONE NUMBERS |
|-----------------|--|--|
| Mexico | Vendo de Mexico Carreta Mexico - Tequisquiapan Km 3.2 San Juan del Rio, Queretaro C.P. 76800 | Tel: (52) 427 2718096 Fax: (52) 427 2718077 |
| Mexico | IMI Cornelius de Mexico, S.A. de C.V. Manual Dublan No. 35 Col. Tacubaya, Deleg. Miguel Hidalgo C.P. 11870 Mexico | Tel: (52 55) 5272-7904 Fax: (52 55) 5273-5949 |
| Central America | SandenVendo America, Inc. 10710 Sanden Drive Dallas, TX 75238-1335 U.S.A. | Tel: (214) 765-9066 Fax: (214) 221-7010 |
| South America | SandenVendo America, Inc. 10710 Sanden Drive Dallas, TX 75238-1335 U.S.A. | Tel: (214) 765-9066 Fax: (214) 221-7010 |